

Optional Hat Box cover  
for plain end riser

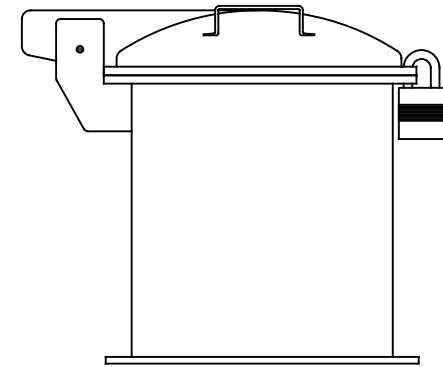

Locking hinged cover  
with bolted tank flange  
([Download locking hinged cover DWG here](#))

Bolted flat cover with bolted tank flange  
and optional 4" locking inspection hatch  
([Download bolted flat cover DWG here](#))

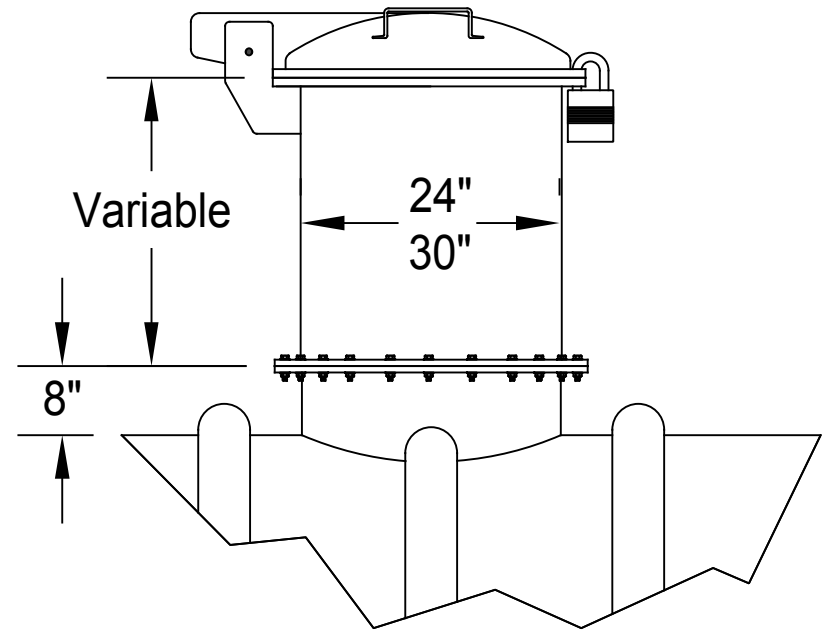
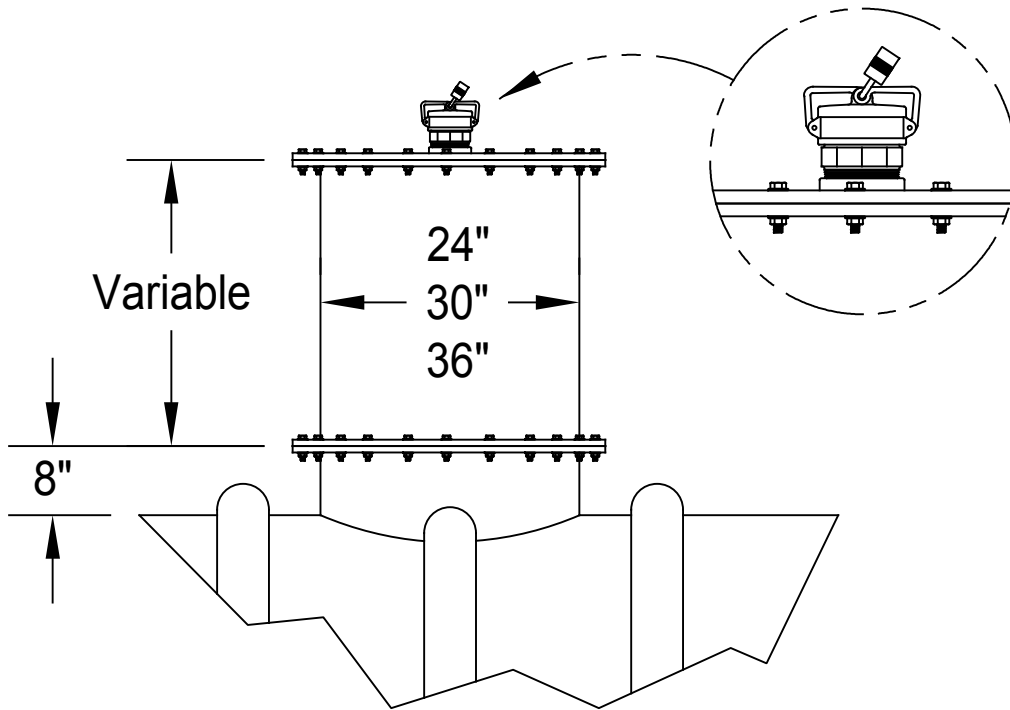

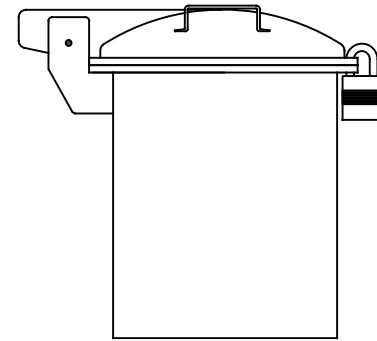
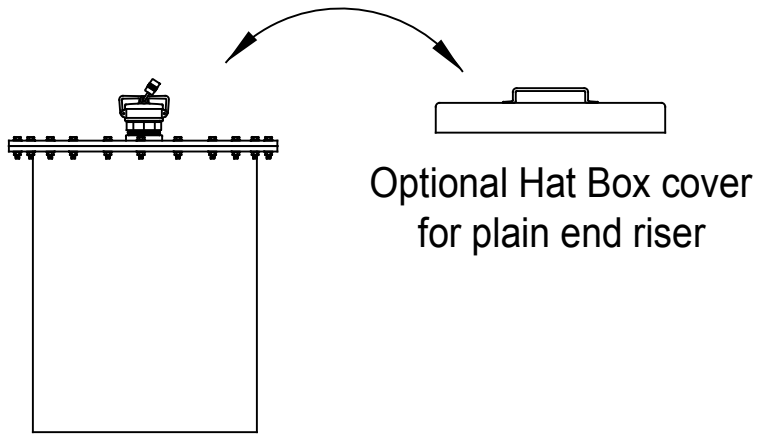

Bolted flat cover with ring collar tank joint  
and optional 4" locking inspection hatch  
([Download bolted flat cover DWG here](#))

Locking hinged cover with ring collar tank joint  
([Download locking hinged cover DWG here](#))

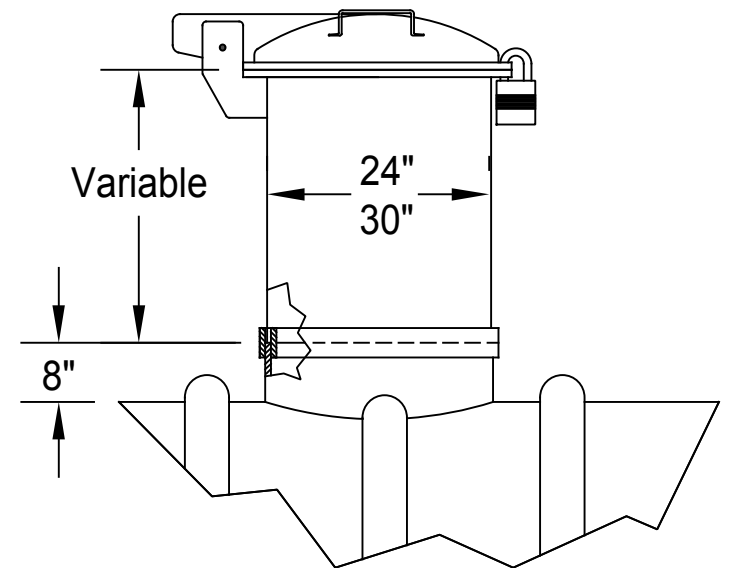
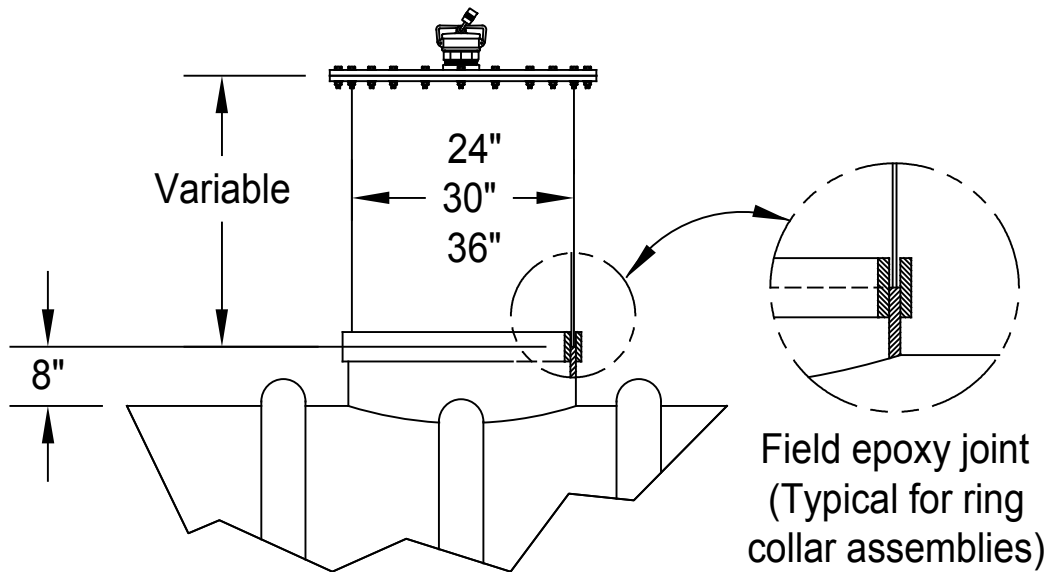

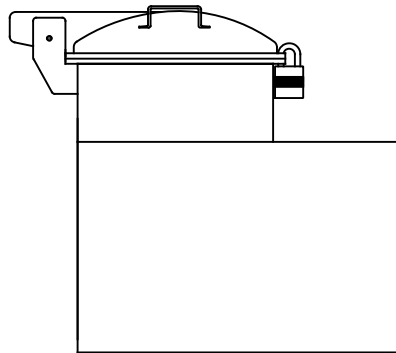

48" full tank penetration ring collar enclosure with offset locking hinged cover (and optional fiberglass ladder)  
 (Download full tank penetration ring collar enclosure DWG here)

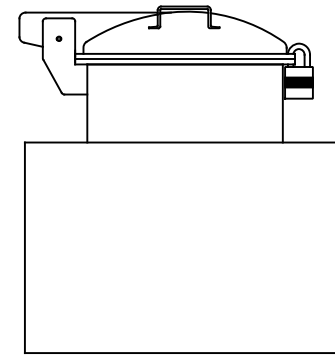

48" ring collar manway enclosure with locking hinged cover and internal bolted 20" manway  
 (Download ring collar manway enclosure DWG here)

