

**MANWAY ACCESSORIES**

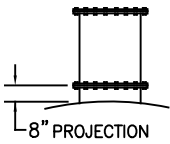

FLANGED MANWAY  
EXTENSION WITH  
BOLTED COVER  
24"-30"-36" DIA.  
UP TO 60" TALL

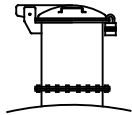

LOCKABLE HINGED  
MANWAY COVER  
AVAILABLE FOR 30" DIA.  
EXTENSIONS ONLY

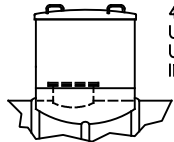

MANWAY ENCLOSURE  
48" DIAMETER  
UP TO 60" TALL  
USING 20" I.D.  
INTERNAL MANWAY

NOMINAL SHIPPING  
WEIGHT: 17,828 POUNDS

KEY	
LIFT LUG	
ANCHOR STRAP	
DEFLECTION PORT	
DEADMAN	

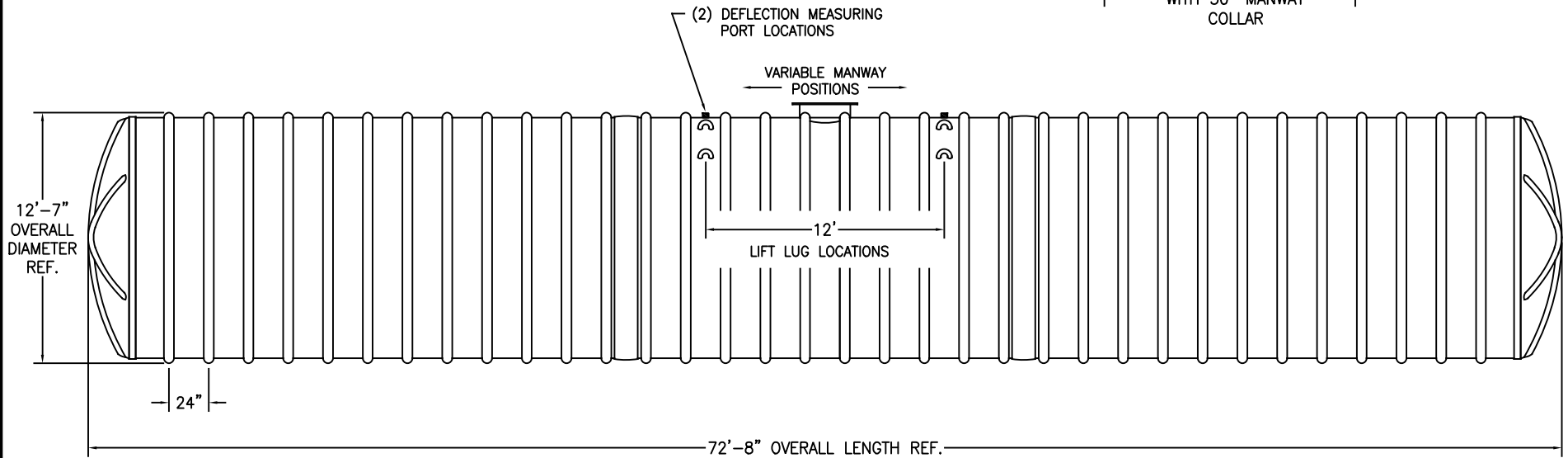
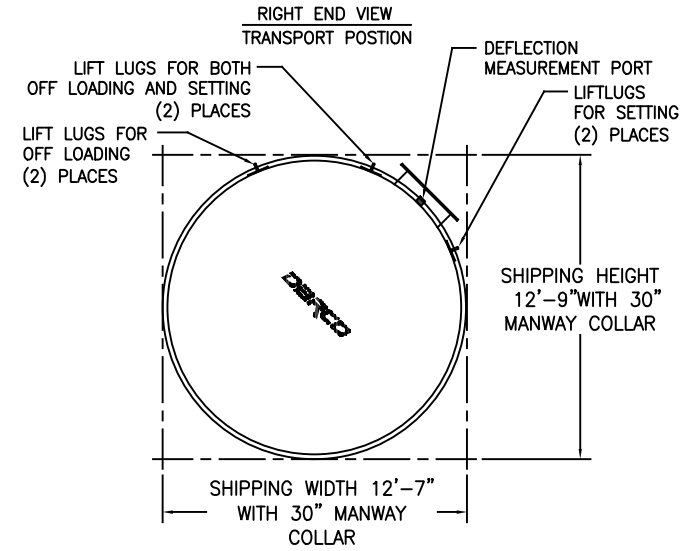

**WARNING**  
MINIMUM SOIL DEPTH ABOVE TANK WHEN USING DEADMAN ANCHORS IS 2 FEET.

**NOTE:**  
THE DECISION TO USE AN ANCHORING SYSTEM IS THE RESPONSIBILITY OF THE OWNER OR HIS REPRESENTATIVE. NOT EVERY TANK WILL REQUIRE ANCHORING.



Rev Date 9/5/2020	12'-0" I.D. 60,000 GAL. FIBERGLASS HORIZONTAL TANK	Sheet 1 of 1
Rev Let INT. REL.	Darco Incorporated Post Office Box 68 Cottonwood, AZ 86326 800-232-8660 - www.darcoinc.com	