

MANWAY ACCESSORIES

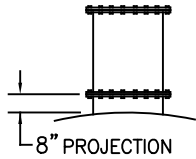

FLANGED MANWAY EXTENSION WITH BOLTED COVER
24"-30"-36" DIA.
UP TO 60" TALL

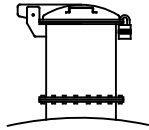

LOCKABLE HINGED MANWAY COVER
AVAILABLE FOR 30" DIA.
EXTENSIONS ONLY

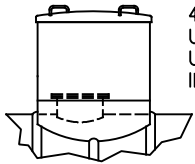

MANWAY ENCLOSURE
48" DIAMETER
UP TO 60" TALL
USING 20" I.D.
INTERNAL MANWAY

NOMINAL SHIPPING WEIGHT: 12,413 POUNDS

| KEY | |
|-----------------|--|
| LIFT LUG | |
| ANCHOR STRAP | |
| DEFLECTION PORT | |
| DEADMAN | |

**RIGHT END VIEW
TRANSPORT POSITION**

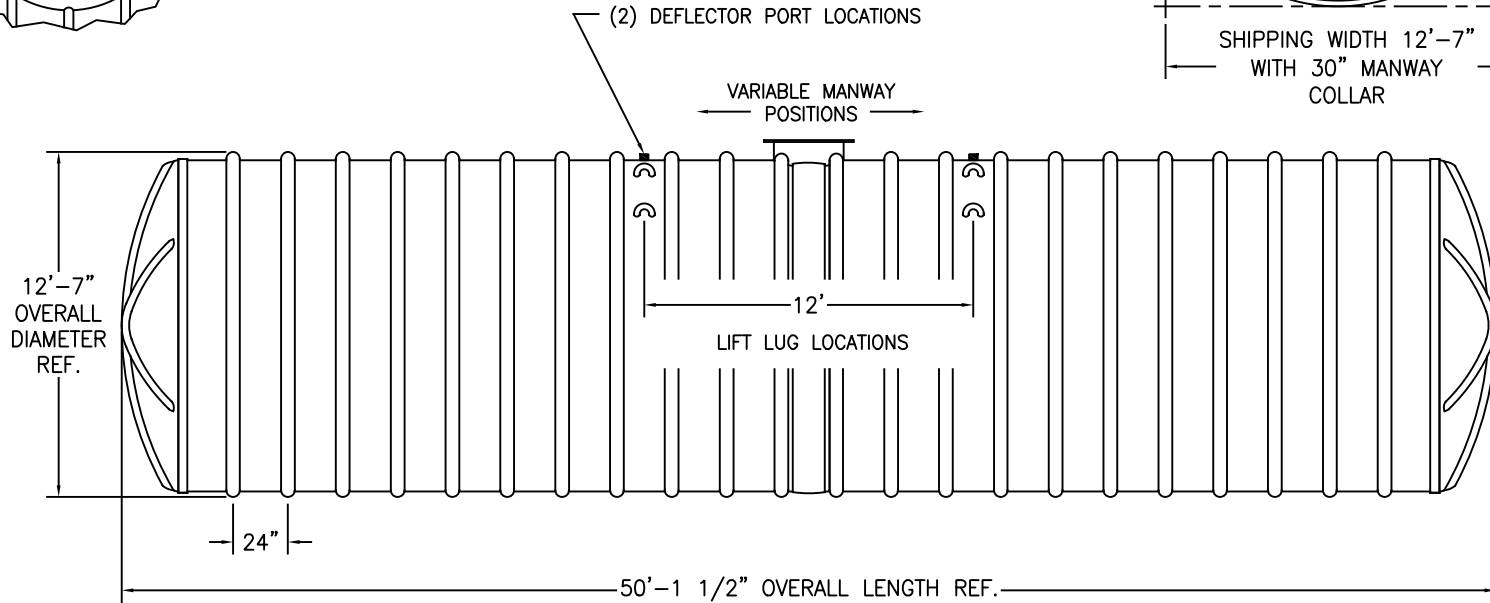
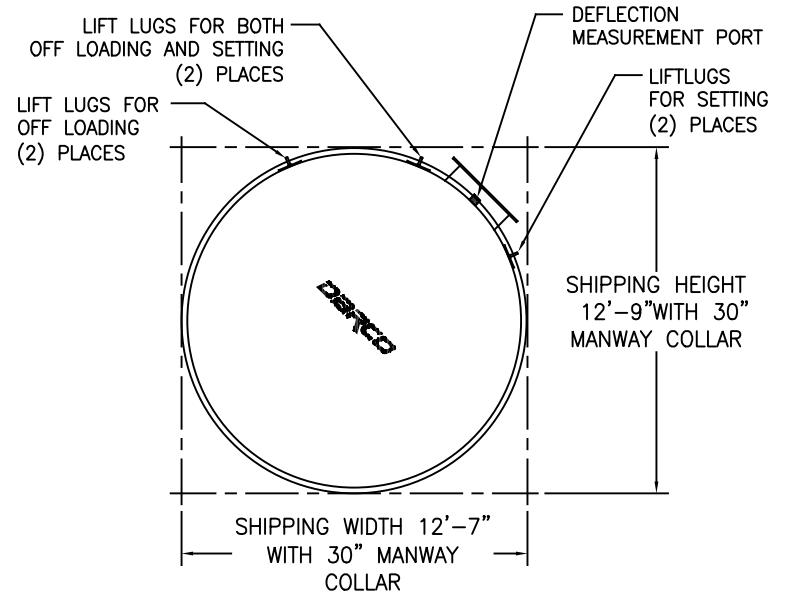

WARNING
MINIMUM SOIL DEPTH ABOVE TANK WHEN USING DEADMAN ANCHORS IS 2 FEET.

NOTE:
THE DECISION TO USE AN ANCHORING SYSTEM IS THE RESPONSIBILITY OF THE OWNER OR HIS REPRESENTATIVE. NOT EVERY TANK WILL REQUIRE ANCHORING.

DARCO INC
FRP UNDERGROUND TANKAGE

| | | |
|----------------------|----------------------------|--------|
| Rev Date 9/5/2020 | 12'-0" I.D. 40,000 GAL. | Sheet |
| Rev Let INT. REL. | FIBERGLASS HORIZONTAL TANK | 1 of 1 |

Darco Incorporated
Post Office Box 68 Cottonwood, AZ 86326
800-232-8660 - www.darcoinc.com